

Revision Level			Revision Record	Changed	Date	Approved	Date
Drawing	State	Part					
01.1	Design Release	-	SEE ECN# 014610	TAT	8/27/18	EJH	8/27/18

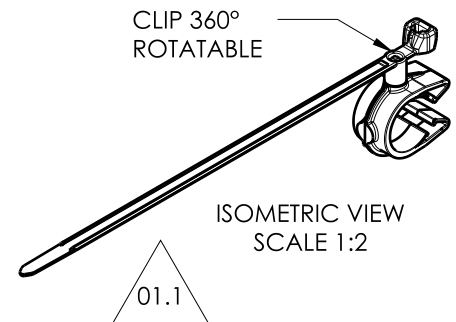
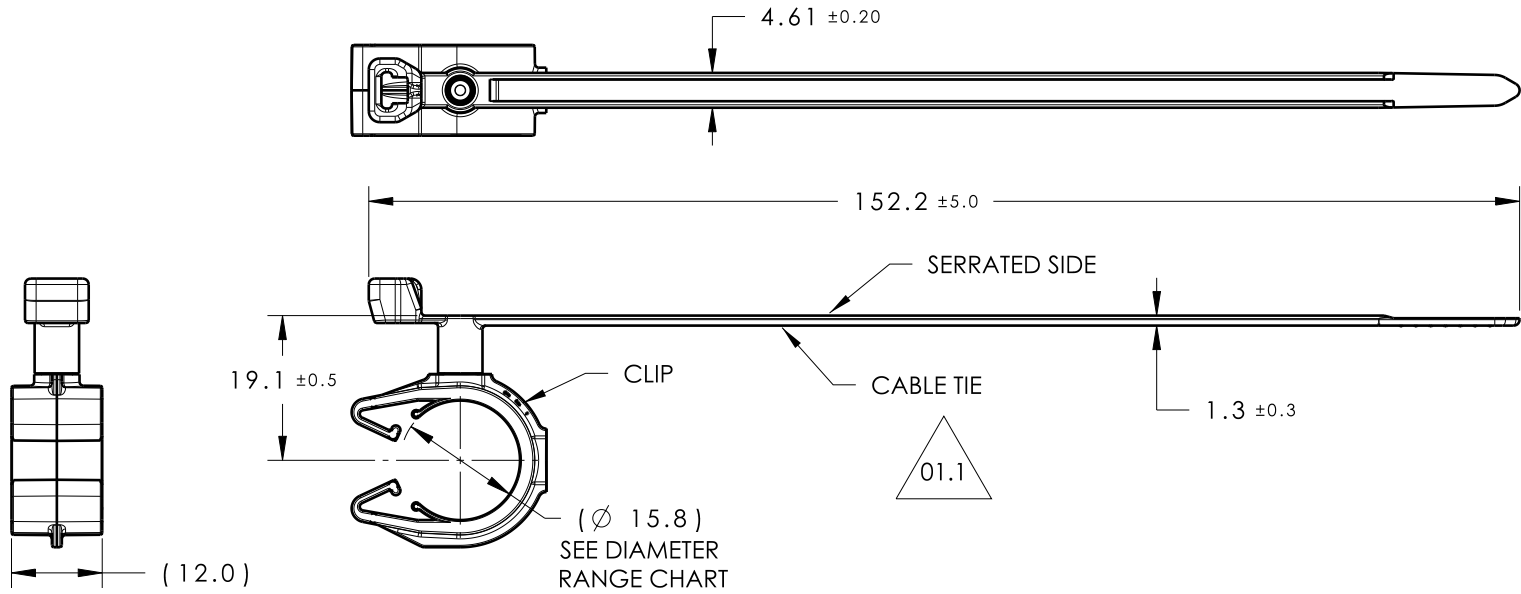

TYPE	SUGGESTED DIAMETER RANGE*
HARNESS	14.0MM - 17.0MM
HOSE	14.0MM - 17.0MM
HARD PIPE/TUBE	15.9MM - 18.3MM

\*RECOMMENDED SIZES MAY DIFFER DEPENDING ON THE APPLICATION, PRODUCT REQUIREMENTS AND MATERIALS USED

\*\*PATENT PENDING 29/582,271

GLOBAL PART DESCRIPTION	BUNDLE RANGE	CABLE TIE			CLIP**		
		DRAWING	MATERIAL	COLOR	DRAWING	MATERIAL	COLOR
T50SVMOC16M-PA66HIRHS-BK	2 TO 35	14-0606-011-CSU	PA66HIRHSUV	BLACK	16-0321-000-CSU	PA66HIRHSUV	BLACK

Material SEE CHART COLOR: SEE CHART	Units	millimeters	The copyright of this drawing is reserved by HellermannTyton. It is issued on condition that it is not reproduced, copied or disclosed to a third party, either wholly or in part, without the consent of HellermannTyton.	Drawn	TAT	4/23/18	Article/Type-No	T50SVMOC16M		Scale	1:1
	Tolerance defined on each dimension	Approved		EJH	4/24/18	Title		T50 TIE STRAP COUPLED TO 16MM MOC		Project Number	16-0321
		<b>HellermannTyton</b> North America Web: www.hellermann.tyton.com			Drawing-No		PRODUCTION : Phase		Format	AH	
							<b>16-0321-202-CSU</b>		Sheet	1/1	